

waltercio caldas

Exhibition from 2nd December 2017 to 3rd February 2018
Opening on Saturday, December 2nd, 2017 from 3pm

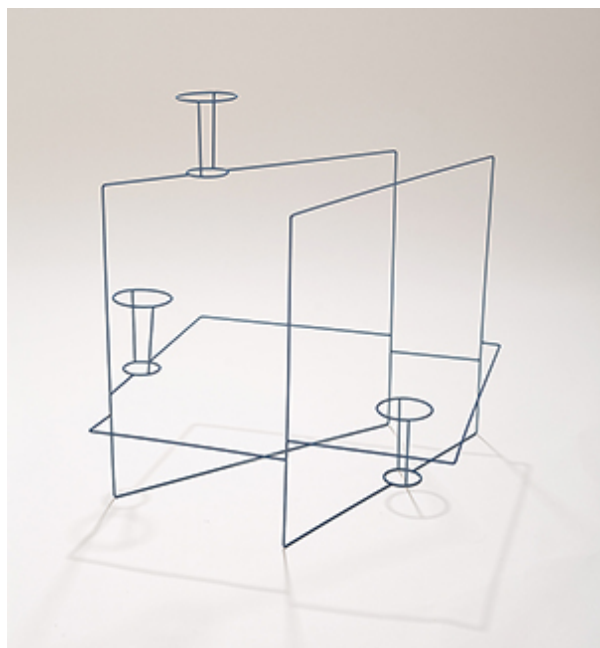

Waltercio Caldas, *Blue glasses*, 2012
Enamel on stainless steel, 62,5 x 60 x 50,5 cm
Photo: Jaime Acioli
Courtesy Galerie Xippas and Galeria Raquel Arnaud

The Xippas gallery is pleased to present a large solo exhibition of Brazilian artist Waltercio Caldas, which will bring together works made in the recent years.

Waltercio Caldas, a major figure of Brazil's contemporary art scene, started his artistic practice in the 1960s, a period marked by the Neo-Concrete movement. For five decades now, the process of perception and the relations between gaze and reflection have been at the heart of his work, where extremely pure and almost minimalist shapes coexist with a conceptual complexity. His sculptures are both present and immaterial and show not so much the objects but rather the space between these objects. As Guy Brett

writes, "the minimum of physical material reveals the maximum latent spatial energy."¹

Waltercio Caldas's sculptures outline objects whose very essence is left undefined. In *Wings* (2008), steel circles hung on the wall, like a kind of anchoring point, and linked together with cotton strings, create geometric shapes both simple and ephemeral. Through the setting up of only lines and points, this piece alludes to emptiness and silence. Its title itself, *Wings*, subliminally recalls air, which, in Caldas's work, is associated with the space structuring the objects, and becomes a location for the projection of thought.

Caldas, who often uses only the contours of objects, as in *Blue glasses* (2012) where steel structures outline glasses without showing the physical objects, pushes the paradox between presence and absence – and between transparency and opacity – to its extreme. This paradox is reinforced through a play on mirrors, a recurrent technique in his work. Here again, the artist develops the idea of reflection without actually employing mirrors. In creating several planes where lines and objects replace the reflections of one another, the artist reveals a three-dimension mirror and materialises the idea of reflection, a process process he considers as a "functional dismantling of the mirror."² Thus Caldas goes beyond the duality between presence and absence, positive and negative, and manages to reach a

¹ Guy Brett, « Taking Liberties » in *Waltercio Caldas, in Conversations with / En Conversacion con Ariel Jimenez*, introduction by Guy Brett, Fundacion Cisneros, New York, 2016, p. 11.

² *Waltercio Caldas, in Conversations with / En Conversacion con Ariel Jimenez*, introduction by Guy Brett, Fundacion Cisneros, New York, 2016, p.76.

paradoxical fusion between a tangible reality and thought.

Language plays a fundamental part in this process of constructing meaning. Because of this essential relation between names and objects, between what we see and what we read, the title becomes an integral part of Waltercio Caldas's work. Language introduces a new approach, that of reading, and also confers another dimension to the word – its physical presence. For instance, in *Not now* (2014), words and steel rods create an inseparable ensemble, enter into a game of repetitions, reflections and transparency.

This use of language, both poetic and conceptual, also allows Caldas to introduce references to art history. The titles of his sculptures often allude to names of artists, such as *Brancusi* (2014), and trigger a reflection on the work of art itself, on the distance between art and art history.

Waltercio Caldas's sculptures, while displaying a rare visual fineness and using such an economy of means, invite the viewers to experience his/her own reading of the work, somewhere between an immediate comprehension and an intellectual interpretation. In the same line as Umberto Eco, who, more than fifty years ago in *The Open Work* (1962), argued that the viewer was now part of the creation process of an art work, Caldas wants to involve his viewer in the experience of interpretation and opens multiple possibilities of meanings. What matters when approaching his work, is the precise and enigmatic moment of perception revealing the work as a process, an echo to phenomenological thought which argued that the object only exists in the eye of the viewer.

Waltercio Caldas was born in Rio de Janeiro in 1946, where he still lives and works.

His first solo exhibition took place at the Modern Art Museum of Rio de Janeiro in 1973 when he was only 27. Numerous museums and art institutions have dedicated exhibitions to his work since, including the Stedelijk Museum, Schiedam, Netherlands (1992), the Calouste Gulbenkian Foundation, Lisbon, Portugal (2008), the Blanton Museum of Art, Austin, United States (2013), the State Pinacoteca in São Paulo, Brazil (2013), etc.

He represented Brazil in the 47th Venice Biennale and took part in the 52nd Venice Biennale in 2007. He also participated in the dOCUMENTA 9 in Kassel (1992) and in the 5th Mercosul Biennial (2005).

His works are included in major collections throughout the world: Centre Georges Pompidou (Paris, France), the Museum of Modern Art (New York, United States), the National Gallery of Art (Washington, United States), the Museum of Modern Art in São Paulo and the Museum of Modern Art in Rio de Janeiro (Brazil), among others.

His monumental public installations are present in numerous countries: Brazil, Uruguay, Spain, Norway, Germany, etc.

GALERIE XIPPAS PARIS

108 rue Vieille du Temple 75003 Paris

www.xippas.com

Mardi - Vendredi : 10h-13h et 14h - 19h

Samedi : 10h - 19h

CONTACT PRESSE

Olga Ogorodova

press@xippas.com

+33 1 40 27 05 55